

AQUA 電磁計量泵 HC899

意大利製造



符合認證標準：

- n° 2004/108/CE Direttiva EMC
- n° 2006/95/CE "DBT Low Voltage Directive"
- n° 2011/65/UE , 2012/19/UE "direttive RoHs e WEEE"
- n°. 2004/108/CE EMC directive
- n°. 2006/95/CE "DBT Low Voltage Directive"
- n°. 2011/65/UE, 2012/19/UE "RoHs and WEEE directives"

流量調節：手動

防護等級：IP65

其他產品：



解說影片：



材質：

部分	標準	可選
泵體 Pump head	PP (HC899 Model 3) PVC (HC899 Model 4)	-
隔膜 Diaphragm	PTFE	-
閥球 Ball valve	Pyrex 玻璃	-
閥體 Valve body	PP (HC899 Model 3) PVC (HC899 Model 4)	-
O 形圈 O-rings	Viton	EPDM
注射閥 Injection valve	PVC - Hastelloy spring - Pyrex	-
底閥 Foot valve	PP (HC899 Model 3) PVC (HC899 Model 4)	-
電壓 Voltage	230 V, 50/60 Hz, 1 ph	-

配件：

包裝：

- 注射閥
- 底閥
- 管
- 安裝支架 (掛牆)
- 安裝支架 (地平面)



IMBALLO/PACK

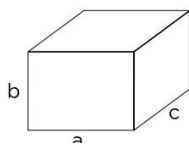

Confezione singola/Single pack:
axbxc: 295x160x350 mm - Kg: 5,50
Confezione multipla/Multipack: 4pz/pcs
axbxc: 375x350x620 mm - Kg: 23,20

AQUA 電磁計量泵 HC151

尺寸:

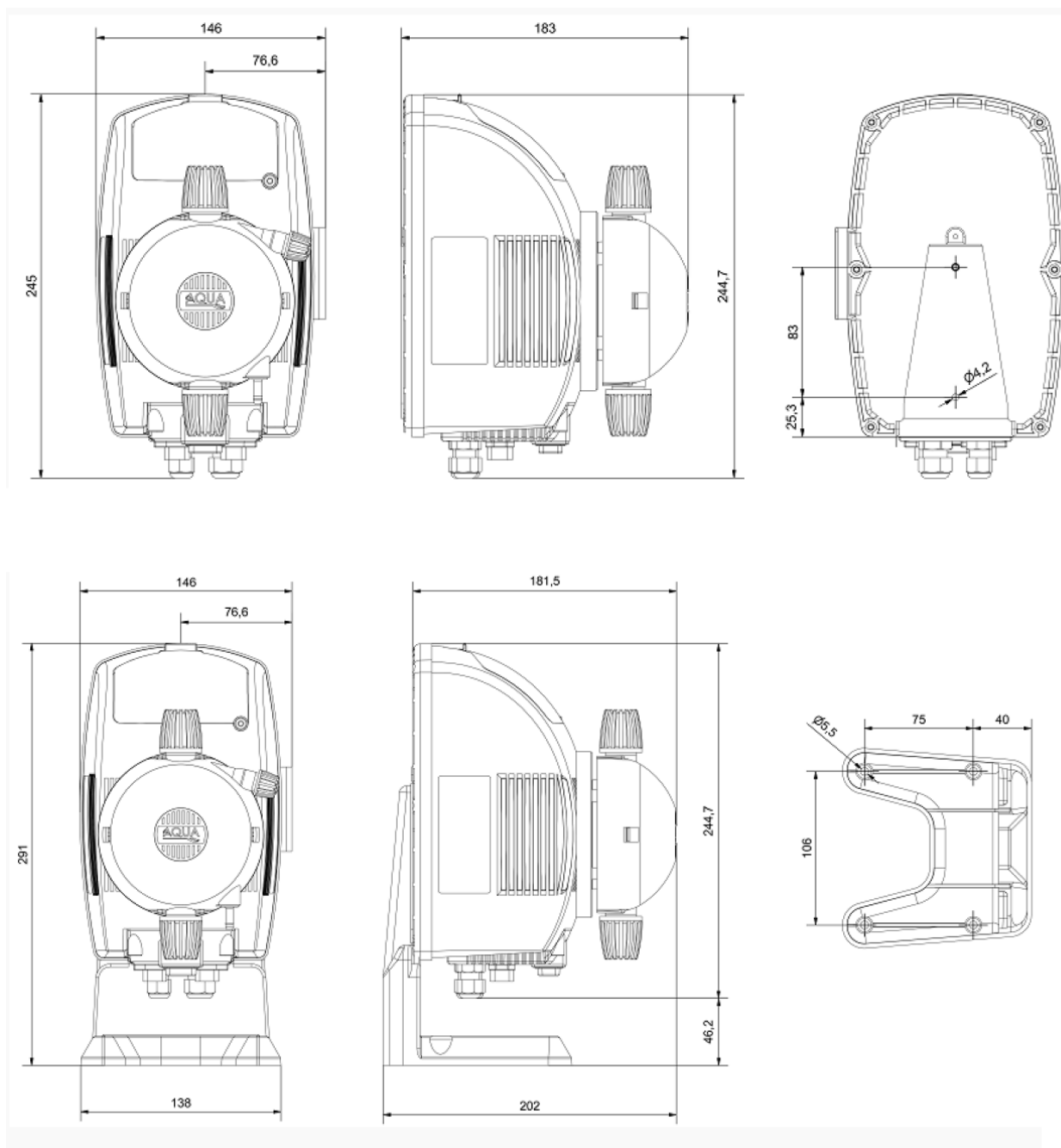

技術參數:

系列	型號	流量 升/小時	壓力 bar	衝程/分鐘	管 內部 x 外部 Ø	平均功耗 Watts
HC899	Model 3	17	5	150	6 x 8 mm	50
		20	3			
		25	1			
	Model 4	25	2.5	150	10 x 14 mm	53
		30	2.2			
		42	1			