

AQUA 電磁計量泵 HC150



意大利製造



符合認證標準：

- n° 2004/108/CE Direttiva EMC
- n° 2006/95/CE "DBT Low Voltage Directive"
- n° 2011/65/UE, 2012/19/UE "direttive RoHs e WEEE"
- n°. 2004/108/CE EMC directive
- n°. 2006/95/CE "DBT Low Voltage Directive"
- n°. 2011/65/UE, 2012/19/UE "RoHs and WEEE directives"

流量調節：手動

防護等級：IP65



其他產品



解說影片

材質：

部分	標準	可選
泵體 Pump head	PP	-
隔膜 Diaphragm	PTFE	-
閥球 Ball valve	Pyrex 玻璃	-
閥體 Valve body	PP	-
O 形圈 O-rings	Viton	EPDM
注射閥 Injection valve	PP - Hastelloy spring - Pyrex	-
底閥 Foot valve	PP	-
電壓 Voltage	230 V, 50/60 Hz, 1 ph	-

技術參數：

系列	型號	流量 升/小時	壓力 bar	衝程/分鐘	管 內部 x 外部 Ø	平均功耗 Watts
HC150	HC150-0	1.5	5	100	4 x 6 mm	14
		2	3			
		3	1			
	HC150-1	2	8	120	4 x 6 mm	14
		5	5			
		7	2			
	HC150-3	3	12	120	4 x 6 mm	16
		4	10			
		5	8			

AQUA 電磁計量泵 HC150

尺寸:

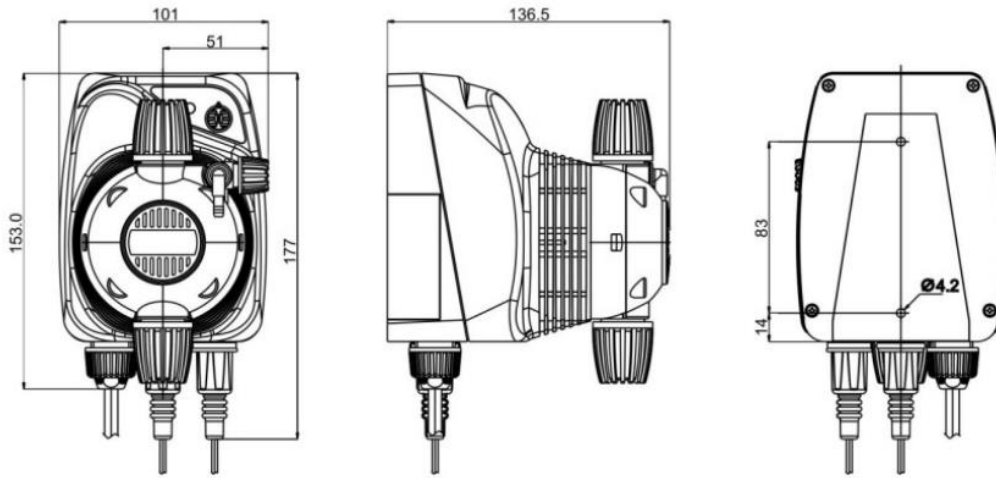

FIG. 1: SERIE "HC150" A MURO – WALL MOUNTING

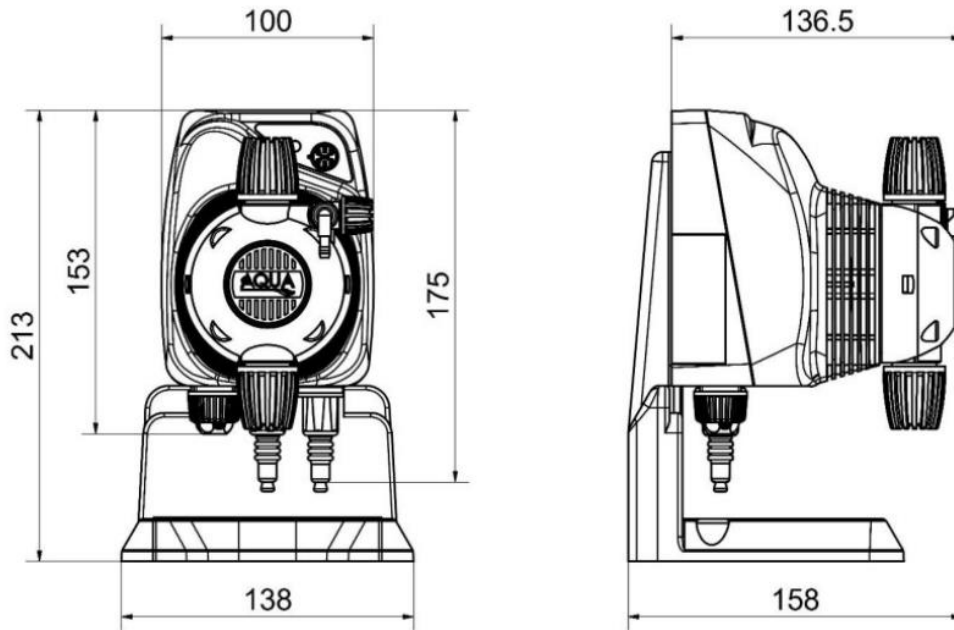

FIG. 2: SERIE "HC150" CON BASE – BASE MOUNTING

配件:

- 注射閥
- 底閥
- 管
- 安裝支架 (掛牆)
- 安裝支架 (地平面)

包裝:



IMBALLO/PACK

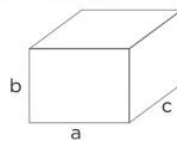

Confezione singola/Single pack:
axbxc: 192x160x250 mm - Kg: 2,33

Confezione multipla/Multipack: 6pz/pcs
axbxc: 405x270x515 mm - Kg: 14,98